

Vac 3 Cubes ■ ■ ■

VACUUM PRODUCTS



Vac 3 Cubes ■ ■ ■

www.vac-cube.com

536 E. Tarpon Ave Suite #5 Tarpon Springs, FL 34689

Phone: 727-944-3337

Fax: 727-945-0079

What is vacuum?

Vacuum exists when atmospheric air is removed from a system resulting in less air pressure within the system than the atmospheric pressure outside the system.

What is vacuum flow?

The rate at which atmospheric air moves out of a system is defined as the vacuum flow rate and is expressed in cubic feet per minute (scfm).

What is vacuum force?

The level of negative pressures defined as vacuum force and expressed in inches of mercury (H.G.).

What is the time of evacuation?

The time required to pump a given system from atmospheric pressure to a specific pressure.

What is the multi-venturi principle?

In its simplest terms, Vac Cubes' multi-venturi employs four nozzles in each pump. The four nozzles are in series from smallest orifice at the pressure side and progressively larger to the exhaust side. With four nozzles, we produce a vacuum in three separate chambers (see cut away), so our multi-venturi pump is actually three separate pumps operating on a single source of compressed air. A multi-venturi pump can deliver two to four times more flow per scfm of compressed air, when compared to a single venturi pump.

What is optimum pressure?

Vac Cubes has designed its venturi to operate at 67 psi for the standard series and 86 psi for the L-series. The optimum pressure creates the highest velocity in the first nozzle. The nozzles are designed to create the highest vacuum and flow rates at specific psi.

What is induced flow?

Induced flow means the amount of SCFM through the vacuum port at the rate level on inches of mercury (H.G.). See the performance tables.

Vac ³ Cubes

Multi Venturi Vacuum
Straight thru flow
Efficient, Reliable

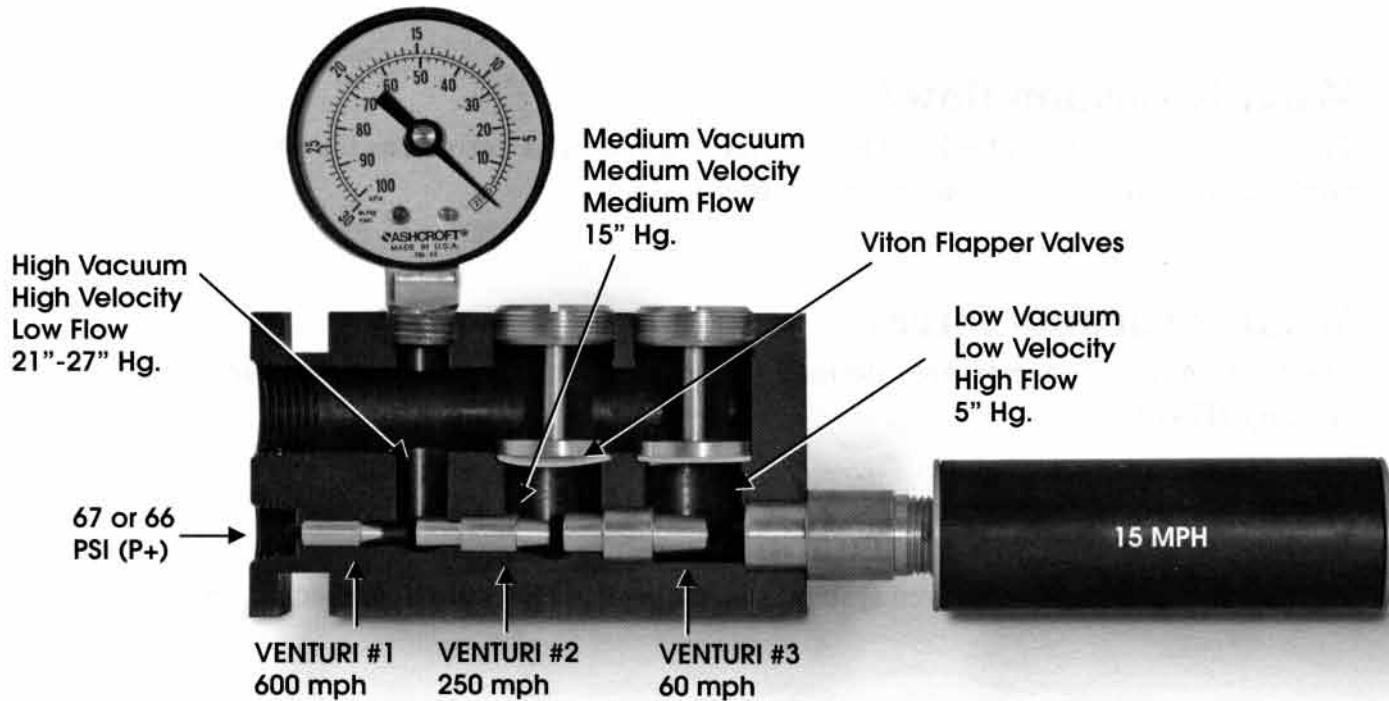

Ten Important Design Features

When compressed air is forced through a conical nozzle, its velocity increases and a principle, discovered by 18th century physicist G. B. Venturi, can be used to generate vacuum economically, without a single moving part.

Multi-Venturi Design: Vac Cubes design of vacuum generators incorporates a series of venturi nozzles. Each nozzle has a progressively larger orifice selected to extract the maximum amount of energy from the compressed air, while optimizing the levels of vacuum generated. Normally, no special prefilters are required because the venturi nozzles are aligned to allow "straight through" air flow. Thus, any air line contaminants easily clear the generator without clogging or building up.

Compressed Air Driven: Vac cubes are easy to install. They operate efficiently on shop air (20 to 90 PSI) and are well suited for explosion-proof applications. There is no RF noise generated to effect electrical-electronic systems either.

Economical to Operate: The innovative Vac Cube multi-venturi design uses less air, yet delivers three to four times more vacuum flow than single venturi units.

Compact Size: Allows pump placement closer to the point of use, Shorter air lines cost less and quicken response time.

Light Weight Construction: Most models weight less than two pounds providing maximum flexibility and mounting ease

Superior Control: Vacuum levels are controlled by adjusting inlet pressure. Pumps can be cycled on and off by controlling inlet pressure, rather than the vacuum line. Thus, there is no wasted energy.

No Moving Parts: Expect extra long pump life with no lubrication required.

Quiet Operation: All multi-venturi pumps come equipped with the Vac Cube straight through designed exhaust silencers. Silencers muffle exhausted air resulting in low noise levels in the 60 - 65 db range, without creating back pressure.

Low Cost: Pricing that is well below foreign imports is only part of the picture, combined with ease of installation, control and maintenance, it means that your

investment is far less when you use Vac Cubes.

All Metal Construction: Vac Cubes uses metal in all parts that are subject to wear, unlike the foreign imports. Nozzles and all port threads are metal, not plastic or just inserts. The only item that needs to be replaced are the standard viton flapper valves.

Quick change Valves: Valves can be replaced using only a screw driver and without removing the pump from its mounted position.

*Use standard series when higher vacuum levels are required on non-porous materials.

*Use L series when higher flows are required on porous materials like cardboard or paper.

MULTI VENTURI DIMENSIONS

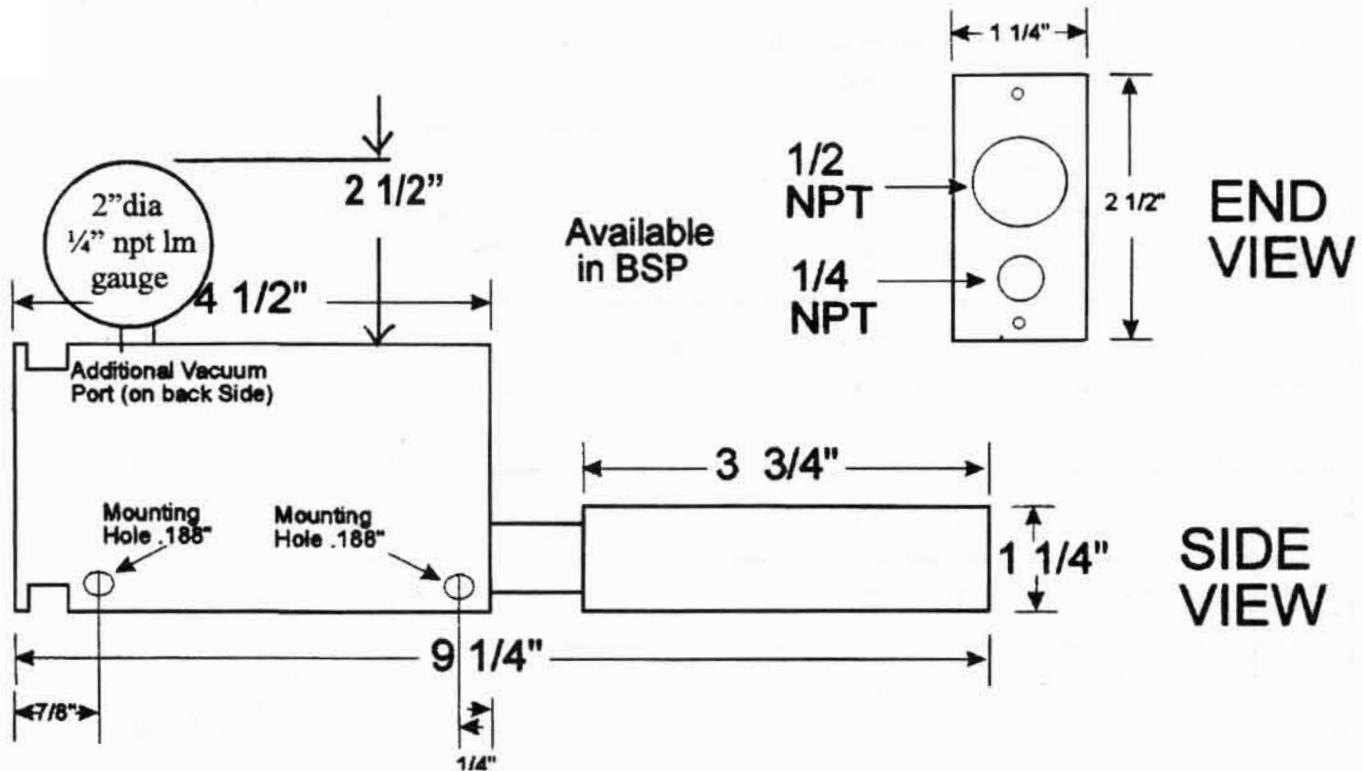

VAC³ CUBES PERFORMANCE TABLES

MODEL #	INDUCED VACUUM FLOW AT INCHES HG IN SCFM										AIR USAGE IN SCFM	OPTIMUM WORKING PRESSURE
	0	1.5	3.0	6.0	9.0	12	15	18	21	24		
60	7.5	5.0	3.0	1.9	.8	.6	.4	.3	.2	.1	2.4	67 PSI
60L	12	9.0	6.1	4.0	2.0	1.8	1.0	.7	.2		3.3	86 PSI
120	11	9.0	6.1	4.0	1.6	1.2	.8	.6	.4	.2	4.6	67 PSI
120L	20	17	9.0	5.5	3.2	2.4	1.6	.4	.2		5.4	86 PSI
180*	16	13	9.0	5.5	2.4	1.9	1.2	.9	.5	.25	6.7	67 PSI
180L*	25	21	15	9.0	4.2	3.2	2.2	1.5	1.0		9.2	86 PSI
240*	21	17.5	9.5	6.5	3.3	2.5	1.7	1.1	.5	.3	7.1	67 PSI

* available in electroless nickel

MANIFOLD MOUNT VENTURI PERFORMANCE CHART												
MODEL #	INDUCED VACUUM FLOW AT INCHES Hg IN SCFM										AIR USAGE IN SCFM	OPTIMUM WORKING PRESSURE
	0	1.5	3.0	6.0	9.0	12	15	18	21	24		
182L	48	42	30	18	8.4	6.4	4.4	3.0	2.0		18.4	86 PSI
184L	96	96	60	36	16.8	12.8	8.8	6.0	4.0		36.8	86 PSI
186L	144	126	90	54	25.2	18	13.2	9.0	6.0		55.2	86 PSI
188L	192	168	120	72	33.6	25.6	17.6	12	8.0		73.6	86 PSI
242	40	35	19	13	6.6	5.0	3.4	2.2	1.0	.6	14.2	67 PSI
244	80	70	38	26	13	10	6.8	4.4	2.0	1.0	28.6	67 PSI
246	120	105	57	39	20	11.5	8.2	6.6	3.0	1.8	43.0	67 PSI
248	160	140	76	54	26	15	10.2	8.8	4.0	2.4	57.0	67 PSI

Manifold Mounted Multi-Venturi

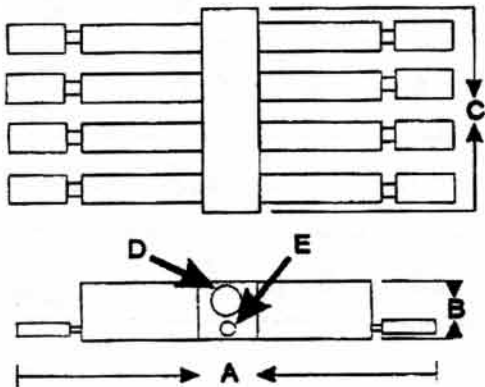
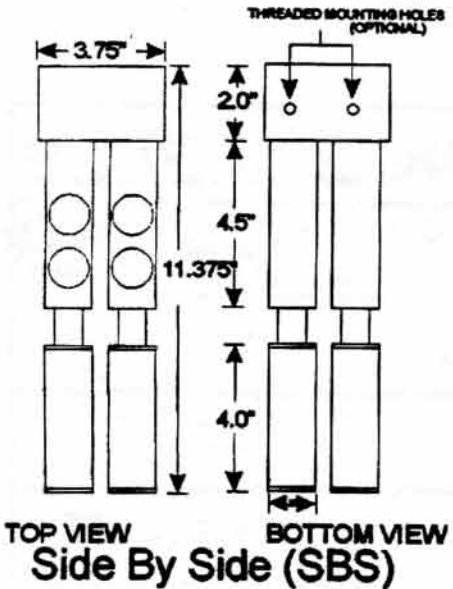

	182L 242	184L 244	186L 246	188L 248
A	11 3/8	21.5	21.5	21.5
B	2.5	3.0	3.0	3.5
C	3 3/4	3.0	5.0	6.5
D	1.0	1.5	1.5	1.5
E	3/8	.50	.50	.50
WT.	5#	10#	14#	17#



SINGLE VENTURI DIMENSIONS

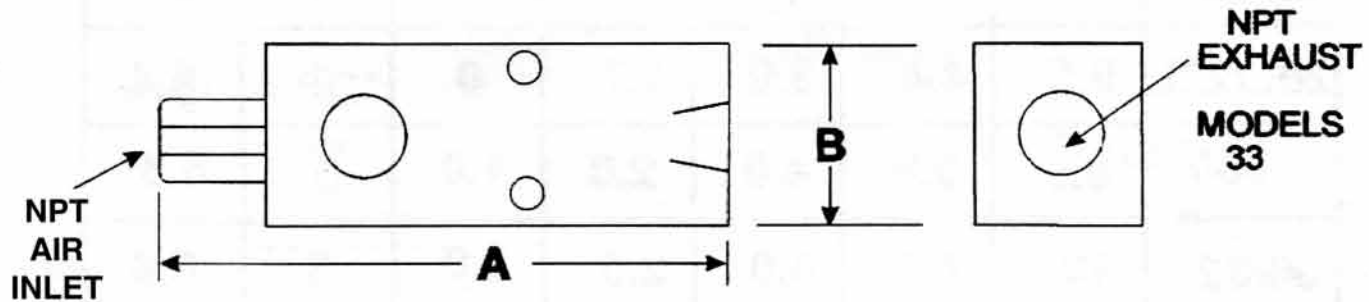
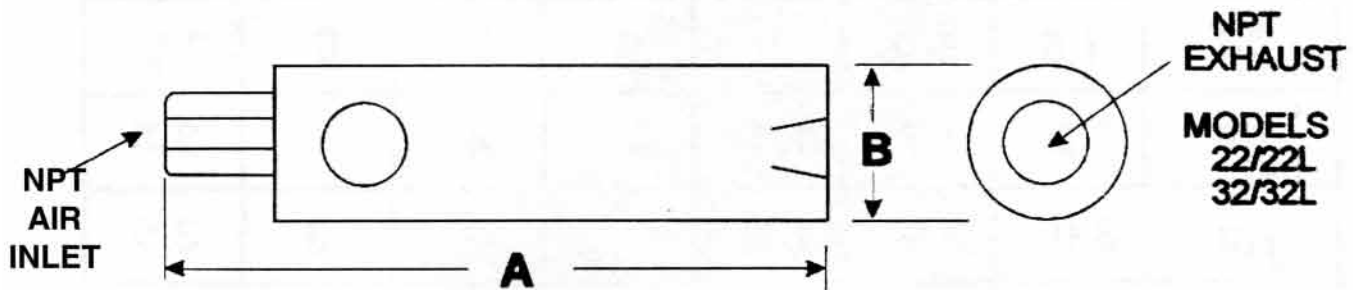
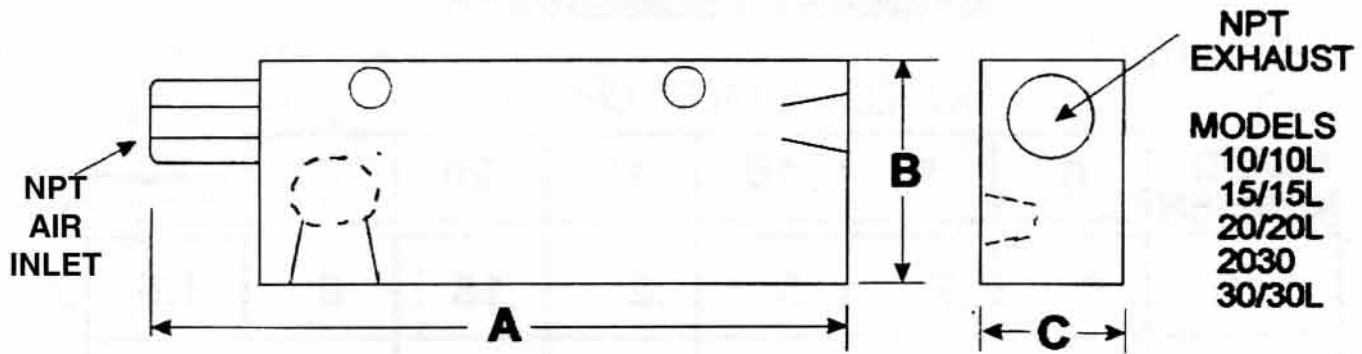

ALL DIMENSIONS ARE IN INCHES

MODEL	A	B	C	INLET	VACUUM	EXHAUST
10/10L	2.5	1.25	.6	1/8	1/8	1/8
*15/15L	3.1	1.3	.6	1/8	1/4	1/4
20/20L 30/30L	4.1	1.5	1.25	1/4	3/8	3/8
22/22L	4.3	1.25	1.25	1/4	3/8	3/8
32/32L	4.3	1.25	1.25	1/4	3/8	3/8
2030	4.3	1.25	1.25	1/4	3/8	3/8
33	3.5	1.0	1.0	1/8	1/8	1/8
MVP	1.5	.5	.5	10/32	10/32	10/32

* available in stainless steel

SINGLE VENTURI FLOW CHART

ALL VACUUM FLOW VALUES ARE LISTED IN SCFM

INCHES OF MERCURY (H.G.)

MODEL NUMBER	INCHES OF MERCURY (H.G.)						AIR CONSUMPTION AT 65 PSI
	0	5	10	15	20	25	
10	.9	.7	.5	.2	.15	0	1.5
10L	1.4	1.1	.8	.3	0	0	1.5
33	1.5	1.2	.9	.6	.3	0	2.5
15	2.2	1.7	1.3	.8	.4	.1	3.5
15L	3.0	2.0	1.5	.9	0	0	3.5
20/22	4.0	3.2	2.4	1.6	.8	.2	6.4
20L/22L	5.5	4.4	3.0	1.7	0	0	6.4
2030	6.9	5.5	4.0	2.0	1.0	0	6.4
30/32	10	7.0	5.0	2.5	2.0	.3	8.6
30L/32L	12	9.0	7.0	3.0	0	0	8.6
MVP	.44	.36	.21	.10	.06	.02	.90



Flat Style Cups

CUPS SHOWN WITH FITTINGS

Figure "A"

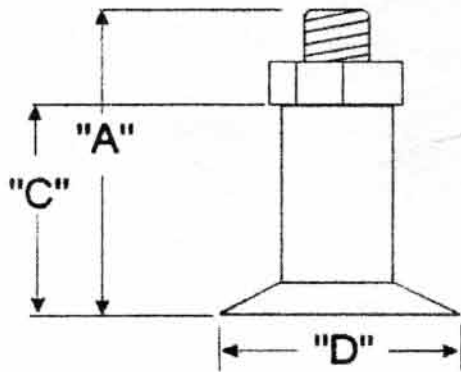

Figure "B"

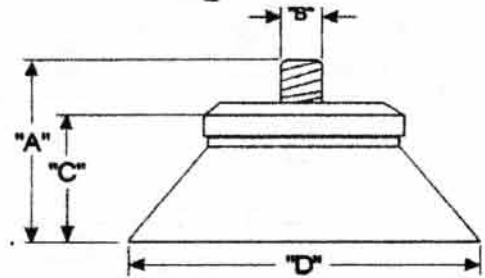

Figure "C"

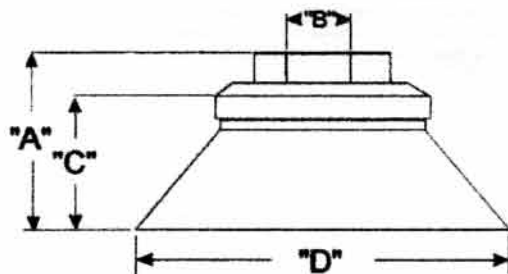
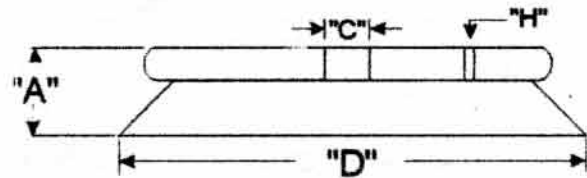

Figure "D"



	HEIGHT WITH FITTING A	THREAD CONNECT B	HEIGHT WITHOUT FITTING C	CUP WIDTH D	VACUUM PORT CONNECT H	DRAWING FIGURE	THREAD TYPE	EFFECTIVE LIFTING AREA
F15	.96	10-32	.50	.80		A	MALE	0.321538
F20	.62	10-32	.319	.80		B	MALE	0.50240
F25	.66	1/8	.370	1.0		B	MALE	0.7850
F30	.70	1/8	.400	1.2		B	MALE	1.13040
F40	.86	1/8	.572	1.6		C	FEMALE	2.00960
F50	1.04	1/8	.726	2.0		C	FEMALE	3.14000
F75	.80	1/2	.528	3.0	10-32	D	FEMALE	7.06500
F110	1.04	1/2	.759	4.4	10-32	D	FEMALE	15.1976
F150	1.28	1/2	1.03	6.0	10-32	D	FEMALE	28.2600

* Add Suffix S for Silicone

* Add Suffix W For Fitting

Bellows Style Cups

CUPS SHOWN WITH FITTINGS Figure "A" Figure "B"

Figure "A"

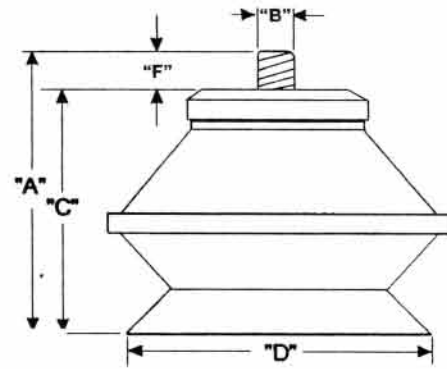
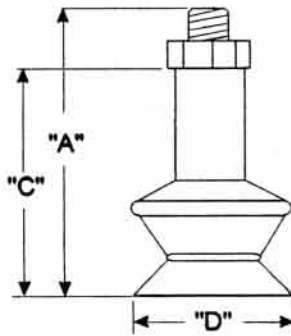

Figure "C"

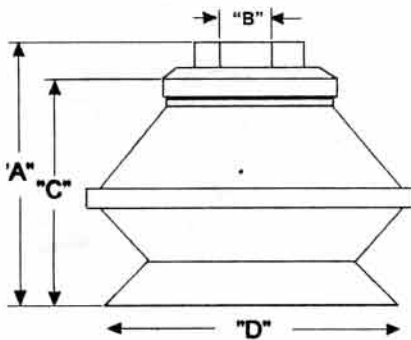
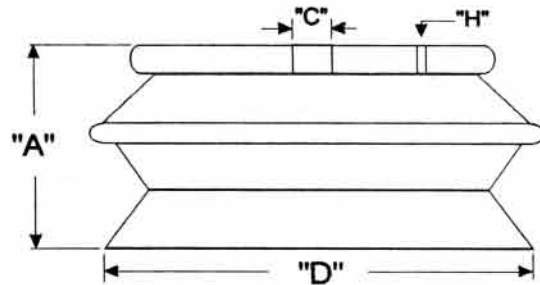

Figure "D"



MODEL	HEIGHT WTH FITTING A	THREAD CONNECT B	HEIGHT WITHOUT FITTING C	CUP WIDTH D	VACUUM PORT CONNECT H	DRAWING FIGURE	THREAD TYPE	EFFECTIVE LIFTING AREA
B10	1.04	10-32	.68	.44		A	MALE	0.151976
B15	1.16	10-32	.80	.64		A	MALE	0.321536
B20	1.06	1/8	.77	.80		B	MALE	0.50240
B30	1.34	1/8	1.04	1.2		B	MALE	1.13040
B40	1.46	1/8	1.08	1.6		C	FEMALE	2.00960
B50	1.74	1/8	1.41	2.0		C	FEMALE	3.14000
B75	1.81	1/2	1.51	3.0	10-32	D	FEMALE	7.06500
B110	2.40	1/2	2.02	4.4	10-32	D	FEMALE	15.1976
B150	3.16	1/2	2.75	6.0	10-32	D	FEMALE	28.2600

* Add Suffix S for Silicone
* Add Suffix W For Fitting

“MB” Multi Bellows Cups

PART NUMBER	HEIGHT WITH FITTING "H"	THREAD CONNECT	CUP HEIGHT ONLY "C"	EFFECTIVE LIFTING AREA
MB20 MB20S	1.290"	1/8 NPT MALE	0.86"	0.50240
MB30 MB30S	1.625"	1/8 NPT FEMALE	1.27"	1.13040
MB40 MB40S	1.985"	1/8 NPT FEMALE	1.64"	2.00960
MB50 MB50S	2.450"	1/8 NPT FEMALE	2.08"	3.14000



Add suffix S to specify Silicone
Add suffix W to order cup with holder

Other suction cups offered by VAC CUBES

VINYL CUPS

OVAL CUPS

8" TO 14" DIAMETER CUPS

DEPANNER (BAKERY) CUPS

SOAP CUPS

SPECIAL FITTINGS



VACUUM FILTERS



Filters are used to protect valves, pumps, ejectors etc. from dust and other harmful particles.

In-line filters are designed to be cleaned without removing the entire strainer from the line, by simply removing the bowl and cleaning or changing the filter element. The transparent nylon bowl lets you easily monitor the condition of the filter element.

Vac Cubes filters range in size from 1/4" to 1 1/2" NPT

Cleaning Requirements

Requirements

All elements can be easily cleaned or replaced without removing the entire strainer from the line by simply removing the bowl.

LOW PROFILE

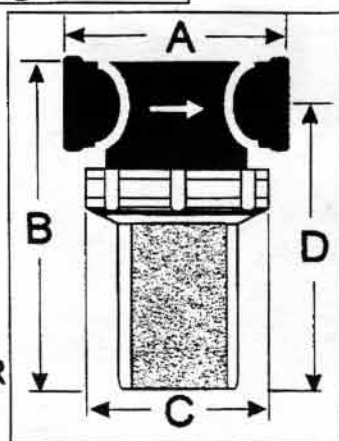
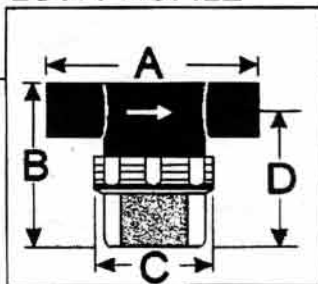

REGULAR & LARGE

Part Number	A	B	C	D	Filter area (sq. inches)	Pipe Thread
FLTP-1/4F	3.06	2.42	1.86	1.98	4.27	1/4" Female
Regular						
FLTP-3/8F						3/8" Female
FLTP-1/2F	3.64	5.35	2.95	4.80	19	1/2" Female
FLTP-3/4F						3/4" Female
Large						
FLTP-1F	4.62	6.36	4.00	5.60	33	1" Female
FLTP-1.25F	5.16	8.10	4.00	6.93	39	1.25" Female
FLTP-1.5F	5.16	8.10	4.00	6.93	39	1.5" Female

SILENCERS

NON CLOGGING FLOW THROUGH



MODEL#	DIA".	OVER ALL LENGTH"
ES2- 1/8M	.75	2.30
ES2-1/4M	.75	2.30
ES2-1/4F	.75	2.25
ES1-3/8F	1.25	3.59
ES1S-3/8F	1.25	2.89
ES1-3/8M	1.25	3.83
ES1S-3/8M	1.25	2.45
ES1-3/8MF	1.25	3.83
ES1-8-3/8MM	1.25	8.45
ES1-1/2M	1.25	3.83
ES1S-1/2M	1.25	2.90

M= MALE NPT THREADS F=FEMALE NPT THREADS S= SHORT
TUBES AND END CAPS ARE ANODIZED ALUMINUM

VACUUM SWITCHES

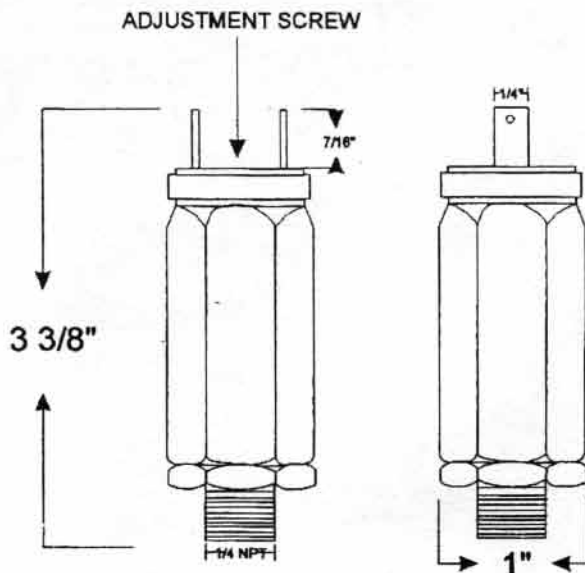

VS-1

- * Adjustable 6-28"
- * Viton diaphragm
- * 10 amp rated
- * .250" spades
- * 1/4" NPT vacuum Connection
- * 1" hex brass body

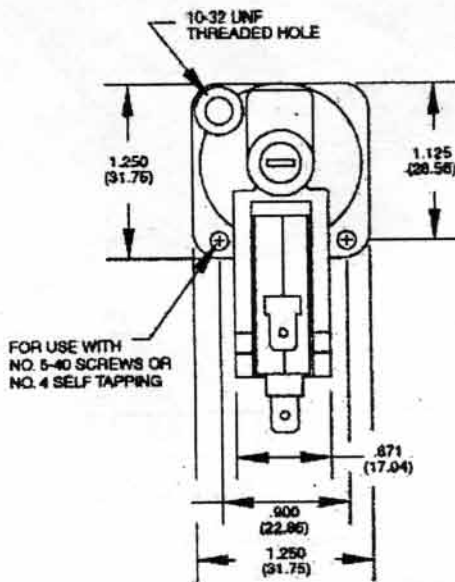

VS-3

- * Adjustable 2-28"
- * Polyurethane diaphragm
- * 1/8-27 NPT vacuum Connection
- * .187" spades
- * 15 amp rated
- * Polysulfone body

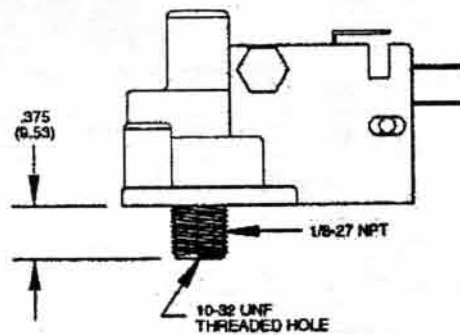

APPLICATIONS

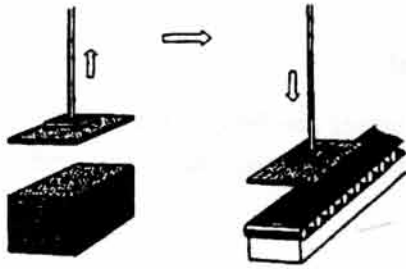

Picking up and handling of sheets of material

Vacuum and suction cups can be used to move sheets of various materials and sizes between different production units.

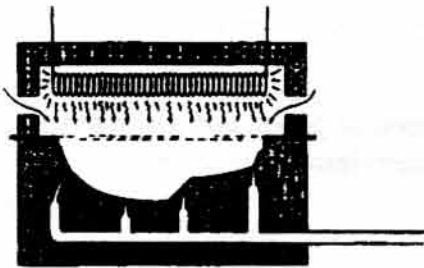

Vacuum molding of plastic products

Vacuum forming uses atmospheric pressure for pressing down heated sheets of plastic into a mold. A vacuum tank can be used for extra force in the initial stage.

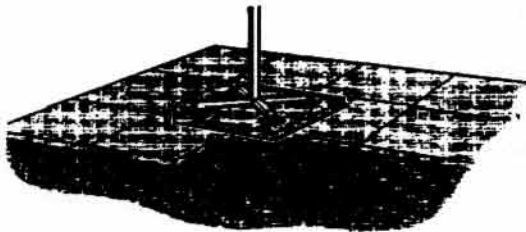

Handling stones and concrete slabs

Using the right suction cup, stone, concrete or other rough slabs can be removed or put in place by means of vacuum.

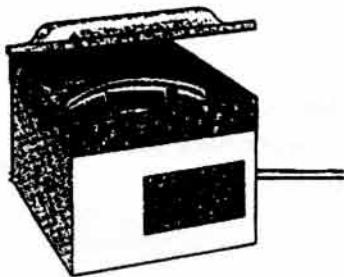

Vacuum packaging

Food that is vacuum packed will typically have a much longer shelf life. The use of vacuum in packaging can also save a great deal of space by compacting the items, e.g. cushions, clothes or foam products.



Lamination with help of vacuum

In connection with the manufacture of veneer, plastic or other laminated products, vacuum is used to eliminate bubbles and increase strength.

APPLICATIONS

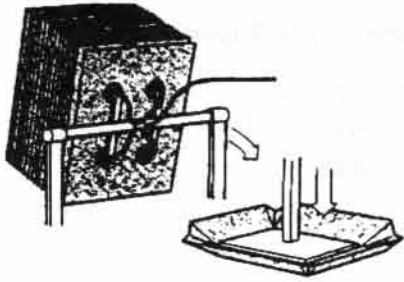

Box forming equipment

Corrugated cartons and boxes can be quickly and easily handled and erected using vacuum pumps and suction cups.

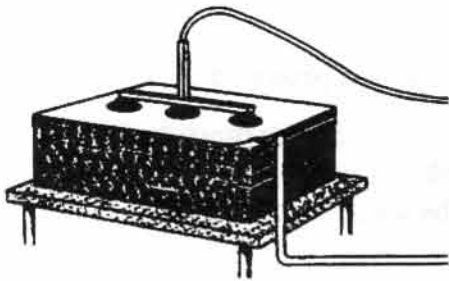

Paper-feeding and printing machines

Compressed air is used in printing machines to blow and thus separate the sheets of paper, and vacuum to pick them up and feed them into the machine.

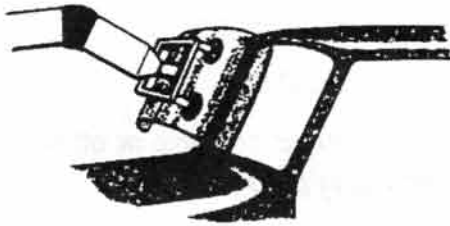

Handling panes of glass by robot within the automotive industry

Using suction cups and vacuum, glass and other easily-damaged materials can be handled simply and conveniently with no risk of scratching or other damage.

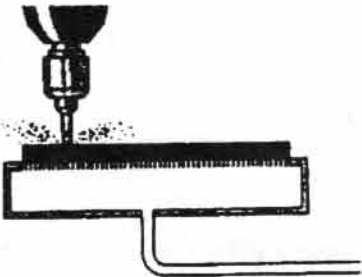

Vacuum fixture

Sometimes called a vacuum "chuck," this fixture uses vacuum to hold a flat workpiece securely in place with minimal risk of any damage.

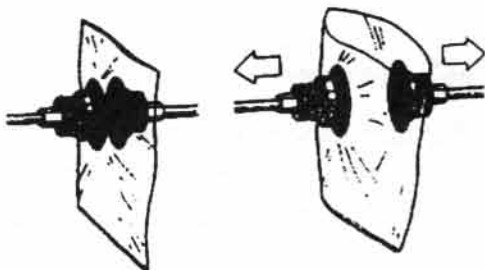

Picking up and opening bags

Bellows suction cups are ideal for picking up and opening all kinds of bags from paper bags to thin plastic bags.

NEW PRODUCTS

BY

Vac 3 Cubes ■ ■ ■



HFT

High Flow Transfer Pump

- 1/8" NPT Porting
- 80 PSI Shop Air
- 1/4" Thru Diameter
- High Flow
- 3.1" Long
- All Aluminum



MVP

Miniture Vacuum Pump

- .5"H x .5"W x 1.5"L
- 10-32 Porting
- Light Weight 1 Ounce
- Maximum Vacuum 24" hg
- Open Flow 0.33 scfm

Pneu Cold

Pneumatic Refrigeration

- 80 PSI Shop Air
- -20 Degrees Ferinheit
- 3 Sizes
- Ideal for Spot Cooling
- No Moving Parts



Vac 3 Cubes ■ ■ ■

www.vac-cube.com

536 E. Tarpon Ave Suite #5 Tarpon Springs, FL 34689

Phone: 727-944-3337

Fax: 727-945-0079